

1838 Uni-Loader
Service Manual

Table of Contents

	Description	Section No.	Form No.
General			
		Tab 1	
	Loctite Product Chart		8-98900
	Torque Specifications	1001	8-71601
	Fluids and Lubricants	1002	7-60550
Engine			
		Tab 2	
	Removal and Installation and Radiator Removal and Installation	2001	7-61400
	Specification Details	2002	7-60560
	Special Service Tools	2003	7-61670
	Kubota Workshop Manual V2203-D1-B		97897-01082
Fuel System			
		Tab 3	
	Fuel System and Filters	3410	7-61640
	Injection Pump Timing	3412	7-61650
Electrical			
		Tab 4	
	Removal and Installation of Electrical Components	4001	7-61410
	Electrical Specifications, Troubleshooting and Schematics	4002	7-60570
	Battery	4003	8-11361
Power Train			
		Tab 6	
	Removal and Installation of Power Train Components	6001	7-61420
	Hydrostatic System Troubleshooting	6002	7-60580
	Piston Pumps	6004	7-61430
	Drive Motors	6005	7-61530
	Pump Drive Coupling	6006	7-61590
	Sprockets Chains and Axles	6007	7-61630
	Wheels and Tires	6008	8-11461
Hydraulics			
		Tab 8	
	Remove and Installation of Hydraulic Components	8001	7-61600
	Hydraulic Schematics, Specifications and Troubleshooting	8002	7-60591
	Cleaning the Hydraulic system and Hydrostatic System	8003	8-11521
	Gear Pump	8004	7-61490
	Loader Control Valve	8005	7-61500
	Auxiliary Control Valve	8006	7-61510
	Self-Leveling Control Valve	8007	7-61520
	Backhoe Control Valve - D100 Backhoe	8008	7-61610
	Cylinders	8009	7-61330
Mounted Equipment			
		Tab 9	
	Control Linkages, Pedals, Levers and Chains	9001	7-60600
	Loader	9002	7-61340
	ROPS Canopy, Seat, Seat Belts and Operators Compartment	9003	7-61350
	Backhoe - D100 Backhoe	9005	7-61680

Section 1001

STANDARD TORQUE SPECIFICATIONS

CASE CORPORATION
700 State Street
Racine, WI 53404 U.S.A.

CASE CANADA CORPORATION
3350 South Service Road
Burlington, ON L7N 3M6 CANADA

Rac 8-71601

© 1994 Case Corporation
Printed in U.S.A.
Issued November, 1991

TABLE OF CONTENTS

TORQUE SPECIFICATIONS - DECIMAL HARDWARE 2

TORQUE SPECIFICATIONS - METRIC HARDWARE 3

TORQUE SPECIFICATIONS - STEEL HYDRAULIC FITTINGS 4

TORQUE SPECIFICATIONS - STEEL HYDRAULIC FITTINGS 5

TORQUE SPECIFICATIONS - DECIMAL HARDWARE

Use the torques in this chart when special torques are not given. These torques apply to fasteners with both UNC and UNF threads as received from suppliers dry, or when lubricated with engine oil. Not applicable if special graphities, Molydisulfide greases, or other extreme pressure lubricants are used.

Grade 5 Bolts, Nuts, and Studs		
		
Size	Pound-Inches	Newton metres
1/4 inch	108 to 132	12 to 15
5/16 inch	204 to 252	23 to 28
3/8 inch	420 to 504	48 to 57
Size	Pound-Feet	Newton metres
7/16 inch	54 to 64	73 to 87
1/2 inch	80 to 96	109 to 130
9/16 inch	110 to 132	149 to 179
5/8 inch	150 to 180	203 to 244
3/4 inch	270 to 324	366 to 439
7/8 inch	400 to 480	542 to 651
1.0 inch	580 to 696	787 to 944
1-1/8 inch	800 to 880	1085 to 1193
1-1/4 inch	1120 to 1240	1519 to 1681
1-3/8 inch	1460 to 1680	1980 to 2278
1-1/2 inch	1940 to 2200	2631 to 2983

Grade 8 Bolts, Nuts, and Studs		
		
Size	Pound-Inches	Newton metres
1/4 inch	144 to 180	16 to 20
5/16 inch	288 to 348	33 to 39
3/8 inch	540 to 648	61 to 73
Size	Pound-Feet	Newton metres
7/16 inch	70 to 84	95 to 114
1/2 inch	110 to 132	149 to 179
9/16 inch	160 to 192	217 to 260
5/8 inch	220 to 264	298 to 358
3/4 inch	380 to 456	515 to 618
7/8 inch	600 to 720	814 to 976
1.0 inch	900 to 1080	1220 to 1465
1-1/8 inch	1280 to 1440	1736 to 1953
1-1/4 inch	1820 to 2000	2468 to 2712
1-3/8 inch	2380 to 2720	3227 to 3688
1-1/2 inch	3160 to 3560	4285 to 4827

NOTE: Use thick nuts with Grade 8 bolts.

TORQUE SPECIFICATIONS - METRIC HARDWARE

Use the following torques when specifications are not given.

These values apply to fasteners with coarse threads as received from supplier, plated or unplated, or when lubricated with engine oil. These values do not apply if graphite or Molydisulfide grease or oil is used.

Grade 8.8 Bolts, Nuts, and Studs		
		
Size	Pound-Inches	Newton metres
M4	24 to 36	3 to 4
M5	60 to 72	7 to 8
M6	96 to 108	11 to 12
M8	228 to 276	26 to 31
M10	456 to 540	52 to 61
Size	Pound-Feet	Newton metres
M12	66 to 79	90 to 107
M14	106 to 127	144 to 172
M16	160 to 200	217 to 271
M20	320 to 380	434 to 515
M24	500 to 600	675 to 815
M30	920 to 1100	1250 to 1500
M36	1600 to 1950	2175 to 2600

Grade 10.9 Bolts, Nuts, and Studs		
		
Size	Pound-Inches	Newton metres
M4	36 to 48	4 to 5
M5	84 to 96	9 to 11
M6	132 to 156	15 to 18
M8	324 to 384	37 to 43
Size	Pound-Feet	Newton metres
M10	54 to 64	73 to 87
M12	93 to 112	125 to 150
M14	149 to 179	200 to 245
M16	230 to 280	310 to 380
M20	450 to 540	610 to 730
M24	780 to 940	1050 to 1275
M30	1470 to 1770	2000 to 2400
M36	2580 to 3090	3500 to 4200

Grade 12.9 Bolts, Nuts, and Studs



Usually the torque values specified for grade 10.9 fasteners can be used satisfactorily on grade 12.9 fasteners.

TORQUE SPECIFICATIONS - STEEL HYDRAULIC FITTINGS

Tube OD Hose ID	Thread Size	Pound- Inches	Newton metres
37 Degree Flare Fitting			
1/4 inch 6.4 mm	7/16-20	72 to 144	8 to 16
5/16 inch 7.9 mm	1/2-20	96 to 192	11 to 22
3/8 inch 9.5 mm	9/16-18	120 to 300	14 to 34
1/2 inch 12.7 mm	3/4-16	180 to 504	20 to 57
5/8 inch 15.9 mm	7/8-14	300 to 696	34 to 79
Tube OD Hose ID	Thread Size	Pound- Inches	Newton metres
3/4 inch 19.0 mm	1-1/16-12	40 to 80	54 to 108
7/8 inch 22.2 mm	1-3/16-12	60 to 100	81 to 135
1.0 inch 25.4 mm	1-5/16-12	75 to 117	102 to 158
1-1/4 inch 31.8 mm	1-5/8-12	125 to 165	169 to 223
1-1/2 inch 38.1 mm	1-7/8-12	210 to 250	285 to 338

Tube OD Hose ID	Thread Size	Pound- Inches	Newton metres
Straight Threads with O-ring			
1/4 inch 6.4 mm	7/16-20	144 to 228	16 to 26
5/16 inch 7.9 mm	1/2-20	192 to 300	22 to 34
3/8 inch 9.5 mm	9/16-18	300 to 480	34 to 54
1/2 inch 12.7 mm	3/4-16	540 to 804	57 to 91
Tube OD Hose ID	Thread Size	Pound- Inches	Newton metres
5/8 inch 15.9 mm	7/8-14	58 to 92	79 to 124
3/4 inch 19.0 mm	1-1/16-12	80 to 128	108 to 174
7/8 inch 22.2 mm	1-3/16-12	100 to 160	136 to 216
1.0 inch 25.4 mm	1-5/16-12	117 to 187	159 to 253
1-1/4 inch 31.8 mm	1-5/8-12	165 to 264	224 to 357
1-1/2 inch 38.1 mm	1-7/8-12	250 to 400	339 to 542

Split Flange Mounting Bolts		
Size	Pound- Inches	Newton metres
5/16-18	180 to 240	20 to 27
3/8-16	240 to 300	27 to 34
7/16-14	420 to 540	47 to 61
Size	Pound- Feet	Newton metres
1/2-13	55 to 65	74 to 88
5/8-11	140 to 150	190 to 203

TORQUE SPECIFICATIONS - STEEL HYDRAULIC FITTINGS

Nom. SAE Dash Size	Tube OD	Thread Size	Pound-Inches	Newton metres	Thread Size	Pound-Inches	Newton metres
O-ring Face Seal End					O-ring Boss End Fitting or Lock Nut		
-4	1/4 inch 6.4 mm	9/16-18	120 to 144	14 to 16	7/16-20	204 to 240	23 to 27
-6	3/8 inch 9.5 mm	11/16-16	216 to 240	24 to 27	9/16-18	300 to 360	34 to 41
-8	1/2 inch 12.7 mm	13/16-16	384 to 480	43 to 54	3/4-16	540 to 600	61 to 68
					Thread Size	Pound-Inches	Newton metres
-10	5/8 inch 15.9 mm	1-14	552 to 672	62 to 76	7/8-14	60 to 65	81 to 88
Nom. SAE Dash Size	Tube OD	Thread Size	Pound-Inches	Newton metres	1-1/16-12	85 to 90	115 to 122
					1-3/16-12	95 to 100	129 to 136
-12	3/4 inch 19.0 mm	1-3/16-12	65 to 80	90 to 110	1-5/16-12	115 to 125	156 to 169
-14	7/8 inch 22.2 mm	1-3/16-12	65 to 80	90 to 110	1-5/8-12	150 to 160	203 to 217
-16	1.0 inch 25.4 mm	1-7/16-12	92 to 105	125 to 140	1-7/8-12	190 to 200	258 to 271
-20	1-1/4 inch 31.8 mm	1-11/16-12	125 to 140	170 to 190			
-24	1-1/2 inch 38.1 mm	2-12	150 to 180	200 to 254			

NOTE: Case Corporation reserves the right to make improvements in design or changes in specifications at any time without incurring any obligation to install them on units previously sold.

Section 1002

1002

FLUIDS AND LUBRICANTS

1838 Uni Loader

TABLE OF CONTENTS

CAPACITIES2

ENGINE OIL RECOMMENDATIONS.....3

MAINTENANCE SCHEDULE.....4

MAINTENANCE LOCATIONS.....5

CAPACITIES AND LUBRICANTS

Engine Oil
 Capacity with filter change8 U.S. quarts (7.5 litres)

Type of oil.....See Engine Oil Recommendations on Page 3

Engine Cooling System
 Capacity.....12 U.S. quarts (11.35 litres)

Type of coolant.....Ethylene glycol and water mixed for lowest ambient temperature at least 50/50 mix

Fuel Tank
 Capacity.....19.5 U.S. gallons (73.8 litres)

Hydraulic System
 Reservoir capacity with filter change6.25 U.S. gallons (23.6 litres)

Reservoir capacity without filter change6 U.S. gallons (22.7 litres)

System capacity10.5 U.S. gallons (39.8 litres)

Type of oil.....Case No. 1 engine oil - SAE 10W-30 mixed with Case HTO additive

When you change the hydraulic oil in the reservoir, you must add 1.5 U.S. quarts (1.4 litres) of Case HTO additive. Case part number B17508.

When you add oil to the hydraulic system, use a mixture of Case HTO additive and SAE 10W-30 engine oil (20 to 1 ratio).

Drive Chain Compartments
 Capacity (each)6 U.S. quarts (5.7 litres)

Type of oil.....Case No. 1 engine oil - SAE 10W-30

ENGINE LUBRICATION

Engine Oil Selection

Case No. 1 Engine Oil is recommended for use in your Uni Loader Engine. Case Engine Oil will lubricate your engine correctly under all operating conditions.

If Case No. 1 Multi-Viscosity or Single Viscosity Engine Oil is not available, use only oil meeting API engine oil service category CE.



292L91



See the chart below for recommended viscosity at ambient air temperature ranges.

NOTE: Do not put Performance Additives or other oil additive products in the engine crankcase. The oil change intervals given in this manual are according to tests with Case lubricants.

Oil Viscosity / Temperature Ranges

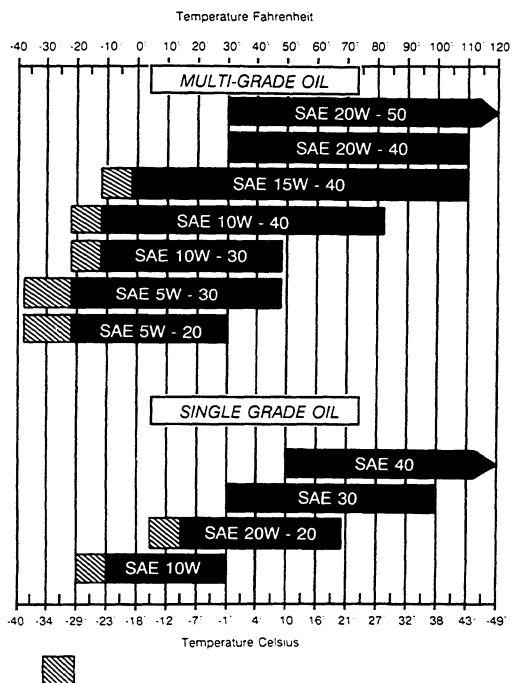

1036L0

NOTE: Use of an engine oil pan heater or an engine coolant heater is required when operating temperatures are in the cross-hatched area.

MAINTENANCE SCHEDULE

AS REQUIRED

- 15. CLEAN DIRT AND DEBRIS FROM THE ENGINE AREA.....
- 4. SERVICE THE AIR CLEANER IF THE AIR CLEANER WARNING LAMP IS ON SEE OPERATORS MANUAL
- 7. CHECK THE WHEEL NUT TORQUE, 115 TO 125 LB FT (156 TO 170 Nm).....SEE SECTION 6008
- 28. REPLACE THE HYDRAULIC FILTER IF THE HYDRAULIC FILTER WARNING LAMP IS ON..... USE CASE FILTERS
- 31. CHECK THE FAN BELT FOR WEAR REPLACE IF DAMAGED

EVERY 10 HOURS OF OPERATION OR EACH DAY

- LUBRICATE THE BACKHOE PIVOT POINTS (8 FITTINGS D100 BACKHOE,
12 FITTINGS D100XR BACKHOE) CASE MOLYDISULFIDE GREASE
- LUBRICATE THE MANURE FORK GRAPPLE (2 GREASE FITTINGS) IF EQUIPPED.
NOT SHOWN CASE MOLYDISULFIDE GREASE
- 17. CHECK AND CLEAN THE HYDRAULIC OIL COOLER.....SEE OPERATORS MANUAL
- 2. LUBRICATE THE LOADER PIVOT POINTS (12 GREASE FITTINGS) CASE MOLYDISULFIDE GREASE
- 5. CHECK THE ENGINE OIL LEVEL.....CASE NO. 1 ENGINE OIL
- 29. CHECK THE HYDRAULIC RESERVOIR OIL LEVEL (SEE NOTE 1).....CASE NO. 1 ENGINE OIL
- 18. CHECK THE ENGINE COOLANT RESERVOIR FLUID LEVEL (SEE NOTE 3).....ETHYLENE GLYCOL AND WATER
- 25. LUBRICATE THE COUPLER WEDGES (2 GREASE FITTINGS) IF EQUIPPED CASE MOLYDISULFIDE GREASE
- 22. CHECK THE CONTROL LINKAGES AND TEST SEAT BAR.....SEE SECTION 9001

EVERY 50 HOURS OF OPERATION

- 23. CHECK THE TIRE AIR PRESSURE AND TIRE CONDITIONSEE SECTION 6008
- 12. DRAIN WATER FROM THE FUEL FILTER..... SEE OPERATORS MANUAL
- 3. CLEAN AND CHECK THE AIR CLEANER DUST VALVE.....SEE OPERATORS MANUAL

EVERY 100 HOURS OF OPERATION

- 20. CLEAN THE SPARK ARRESTER MUFFLERSEE OPERATORS MANUAL
- 13. CHANGE ENGINE OIL AND REPLACE THE ENGINE OIL FILTER..... CASE NO. 1 ENGINE OIL, USE CASE FILTERS

EVERY 250 HOURS OF OPERATION

- 8. CLEAN THE BATTERY AND CHECK THE BATTERY FLUID LEVEL ADD DRINKING OR DISTILLED WATER
- 1. CHECK THE RADIATOR COOLANT LEVEL (SEE NOTE 3)ETHYLENE GLYCOL AND WATER
- 9. CHECK THE DRIVE CHAIN TENSION (EACH SIDE)SEE SECTION 9001
- 24. LUBRICATE THE CASE COUPLER LATCH PIVOTS (2 GREASE FITTINGS)
IF EQUIPPED CASE MOLYDISULFIDE GREASE
- 27. LUBRICATE THE LOADER CROSS SHAFT PIVOT (1 GREASE FITTING)..... CASE MOLYDISULFIDE GREASE

EVERY 500 HOURS OF OPERATION

- 6. INSPECT THE ROPS.....SEE OPERATORS MANUAL
- 28. REPLACE THE HYDRAULIC OIL FILTER..... USE CASE FILTERS
- 10. CHANGE THE CHAIN COMPARTMENT OIL (EACH SIDE) CASE NO. 1 ENGINE OIL (SAE 10W-30)

EVERY 1000 HOURS OF OPERATION

- 19. DRAIN WATER FROM THE FUEL TANKSEE OPERATORS MANUAL
- 30. CHANGE THE HYDRAULIC OIL (SEE NOTE 2) CASE NO. 1 ENGINE OIL
- 14. CHECK THE ENGINE VALVE CLEARANCE SEE SERVICE MANUAL

EVERY 2000 HOURS OF OPERATION

- 16. DRAIN, FLUSH AND REFILL THE ENGINE COOLING SYSTEM (SEE NOTE 3)ETHYLENE GLYCOL AND WATER
- 4. REPLACE THE AIR CLEANER ELEMENTS USE CASE FILTERS

NOTE 1: *When adding oil to the hydraulic reservoir between oil changes, use a mixture of Case HTO additive and SAE 10 W-30 engine oil. Completely mix one U.S. quart of Case HTO additive to 5 U.S. gallons (19 litres) of SAE 10W-30 oil (20 to 1 ratio).*

NOTE 2: *When changing the hydraulic oil in the reservoir, add 1.5 U.S. quarts (1.4 litres) of Case HTO additive (Case Part No. B17508).*

NOTE 3: *Use Ethylene Glycol and water that is mixed 50/50. When adding coolant to the engine, use this mixture.*

MAINTENANCE LOCATIONS

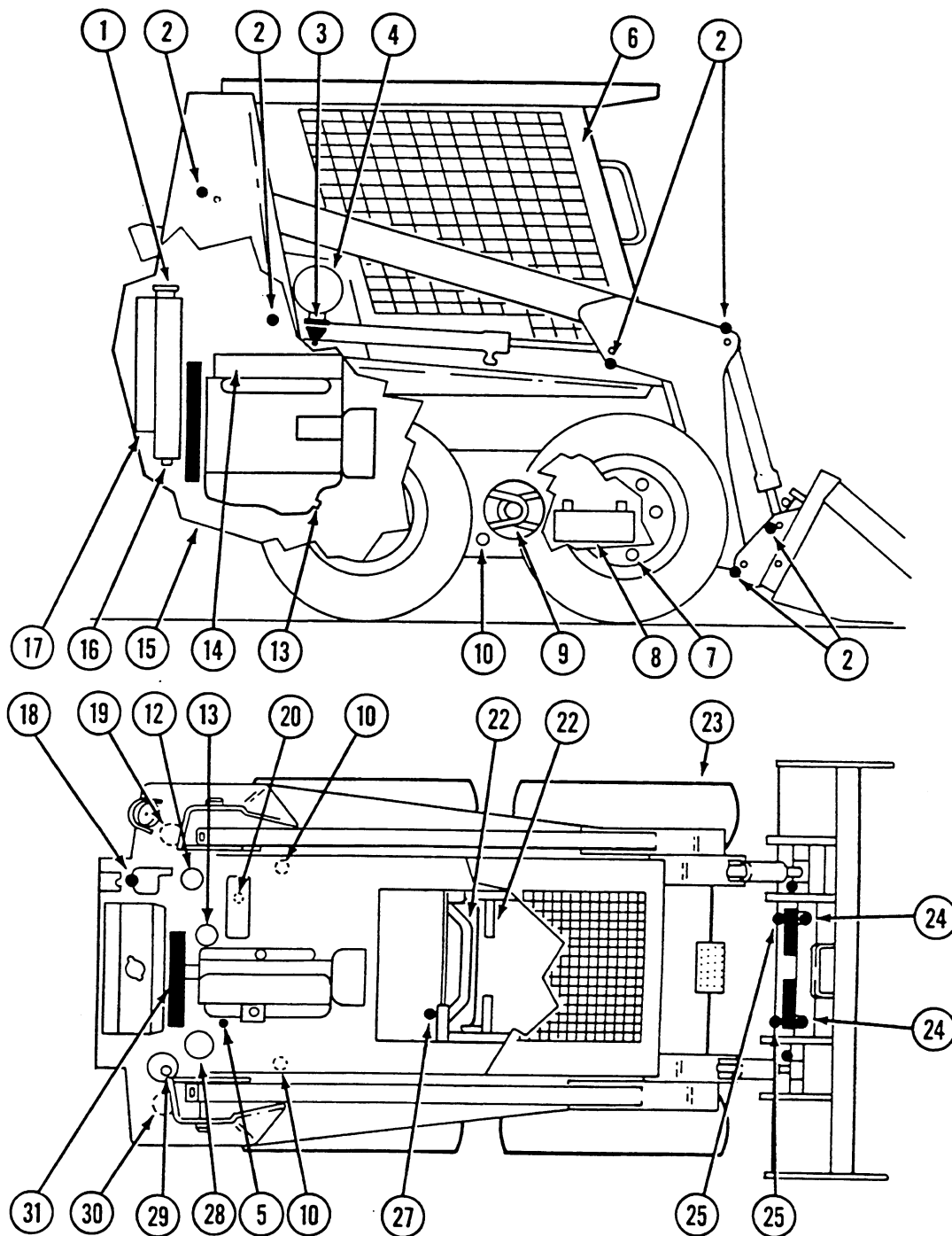

894L93

IF YOU OPERATE THE MACHINE IN SEVERE CONDITIONS, LUBRICATE AND SERVICE THE MACHINE MORE FREQUENTLY. IT IS RECOMMENDED THAT YOU SEE YOUR CASE DEALER FOR INFORMATION ON THE SYSTEMGARD LUBRICATION ANALYSIS SYSTEM.

SEE YOUR OPERATORS MANUAL FOR MAINTENANCE OF SAFETY RELATED ITEMS AND FOR DETAILED INFORMATION OF THE SERVICE ITEMS ON THIS CHART. OPERATORS AND SERVICE MANUALS ARE AVAILABLE FOR THIS MACHINE FROM YOUR CASE DEALER.

NOTE: The CASE CORPORATION reserves the right to make improvements in design or changes in specifications at any time without incurring any obligation to install them on units previously sold.

Section

2001

**ENGINE REMOVAL AND INSTALLATION AND
RADIATOR REMOVAL AND INSTALLATION**

2001

TABLE OF CONTENTS

SPECIFICATIONS	3
SPECIAL TORQUES	3
SPECIAL TOOLS	3
ENGINE REMOVAL	4
ENGINE INSTALLATION	11
RADIATOR REMOVAL	19
RADIATOR INSTALLATION	21

SPECIFICATIONS

Cooling system capacity 12 U.S. quarts (11.3 litres)

SPECIAL TORQUES

Front engine mounts.....80 to 96 pound-inches (109 to 130 Nm)

Rear engine mount..... 150 to 180 pound-inches (203 to 244 Nm)

Cap screws that fasten the tandem pump to the pump mounting plate Apply 271 Loctite on the threads and tighten to 38 to 42 pound-feet (52 to 57 Nm)

Cap screws that fasten the radiator mounting brackets 15 to 20 pound-inches (1.68 to 2.25 Nm)

SPECIAL TOOLS

Order special tools from one of the following addresses

In the U.S.A. and Canada

OTC Division SPX Corporation
655 Eisenhower Drive
Owatonna, MN 55060

In Europe

VL Church Ltd.
P.O. Box 3, Daventry
Northants, NN11 4NF
England

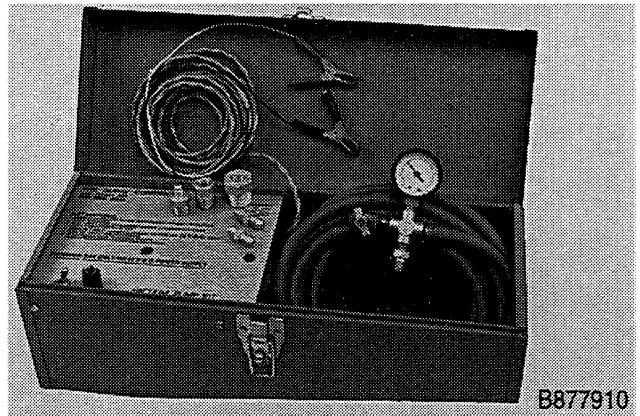

B877910

CAS-10192 Vacuum Pump

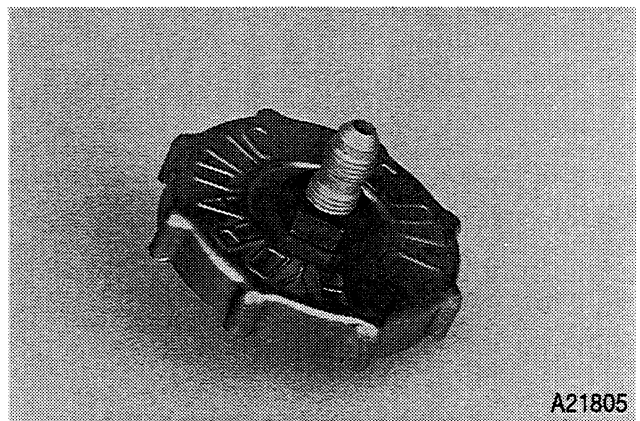

A21805

CAS-1871 Adapter

ENGINE REMOVAL

STEP 1

Move the operators compartment forward according to the instructions in Section 9003.

STEP 2



Open the rear door.

STEP 3

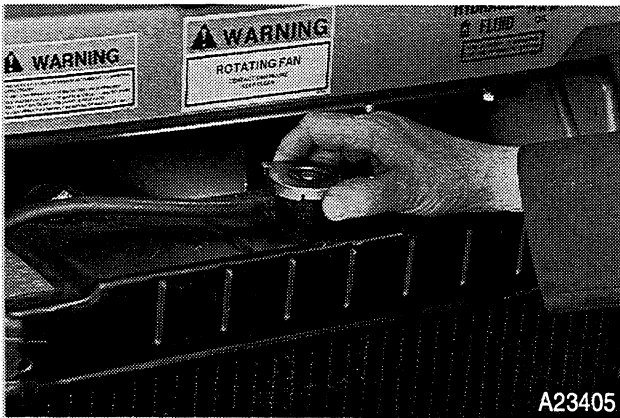

Remove the radiator cap.

STEP 4

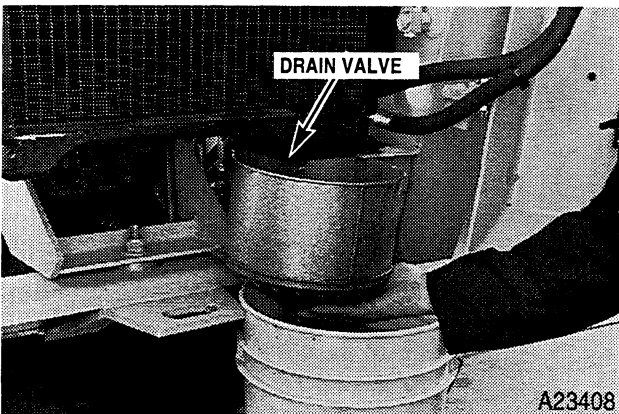

Open the drain valve and drain the cooling system. The cooling system capacity is approximately 12 U.S. quarts (11.3 litres) of coolant.

Rac 7-61400

STEP 5

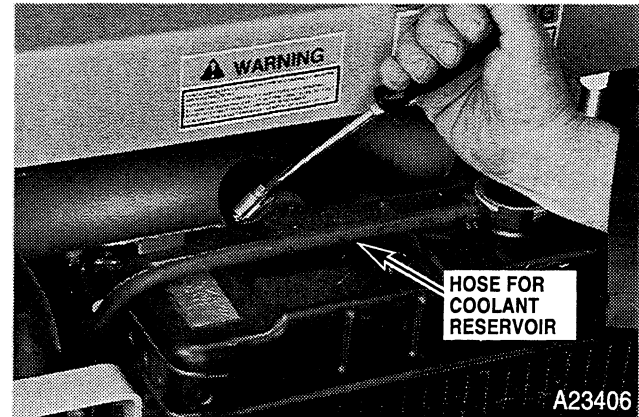

Loosen the clamp and disconnect the top hose from the radiator. Disconnect the hose for the coolant reservoir from the radiator. Install a plug in the coolant reservoir hose.

STEP 6

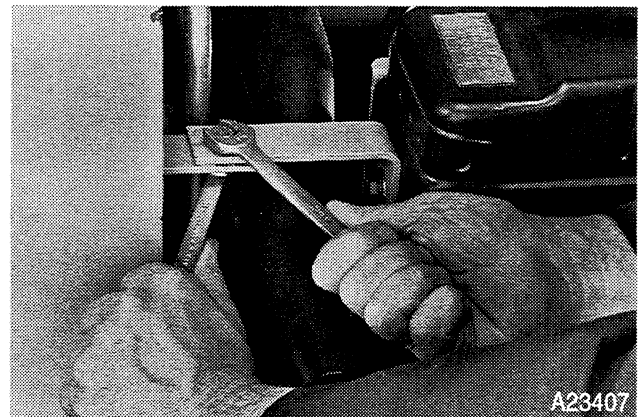

Loosen and remove the self-locking nut, flat washer and bolt that fasten the top left radiator support to the frame.

STEP 7

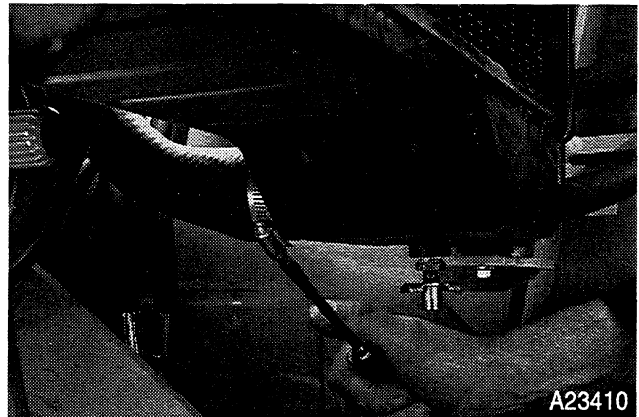

Loosen the clamp and disconnect the bottom hose from the radiator.

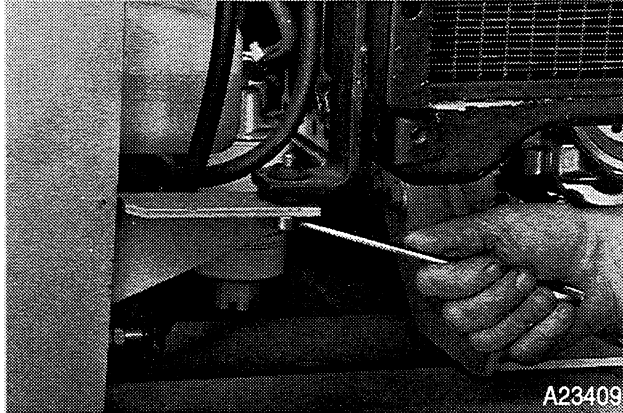
STEP 8

Loosen and remove the cap screw and flat washers that fasten the radiator to the left radiator mounting bracket.

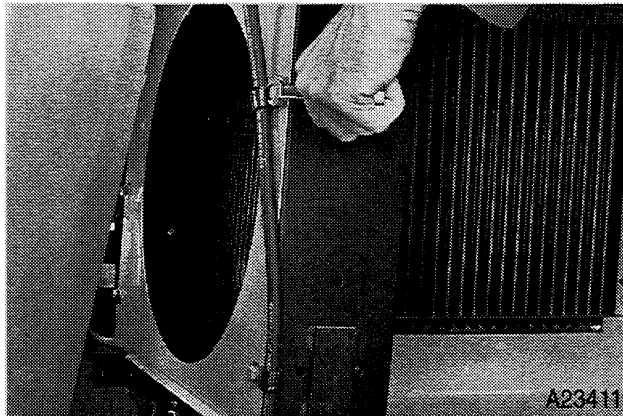
STEP 9

Pull the left side of the radiator to the rear. Loosen and remove the cap screws and flat washers that fasten the clamps for the coolant reservoir hose to the radiator. Put the hose for the coolant reservoir out of the way.

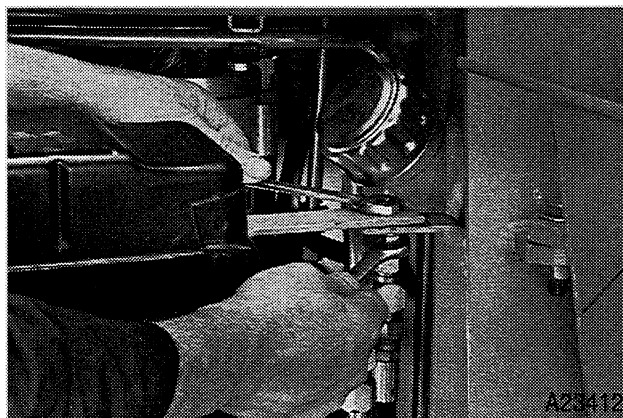
STEP 10

Loosen and remove the hardware that fastens the right side of the radiator to the frame and the radiator upper and lower mounting bracket.

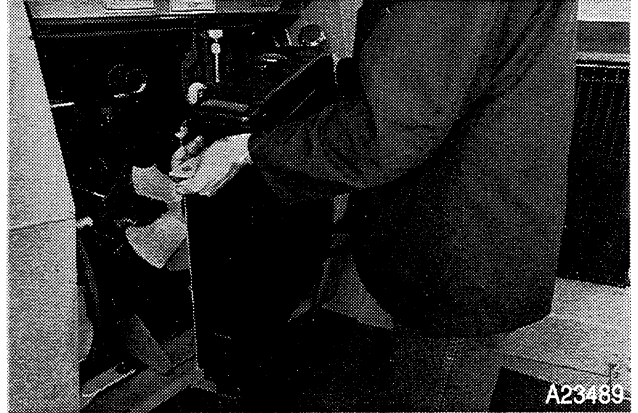
STEP 11

Remove the radiator from the machine.

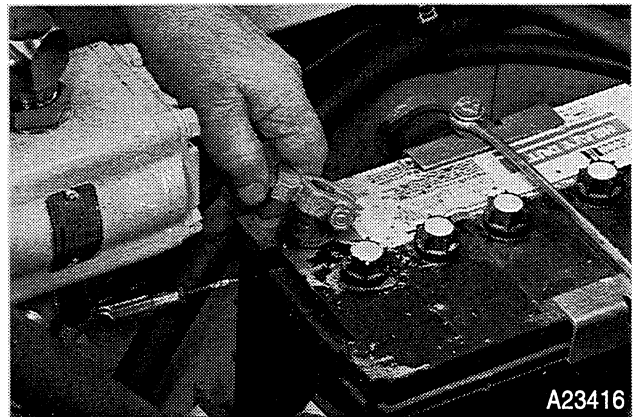
STEP 12

Disconnect the ground cable from the negative post on the battery.

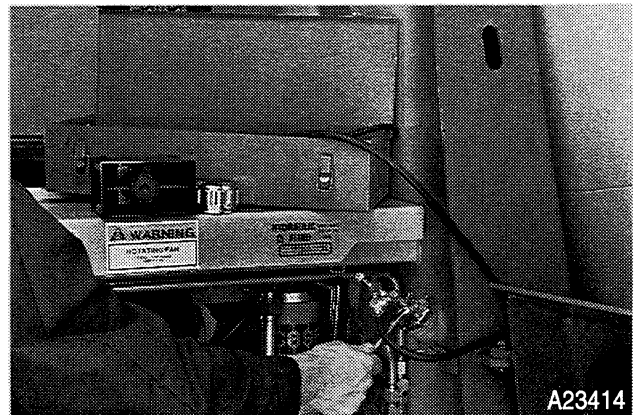
STEP 13

Install the CAS-1871 adapter on the hydraulic reservoir in place of the breather cap and connect the CAS-10192.

STEP 14

Turn the CAS-10192 vacuum pump ON to hold the hydraulic fluid in the reservoir while disconnecting and plugging the hydraulic lines.

STEP 15

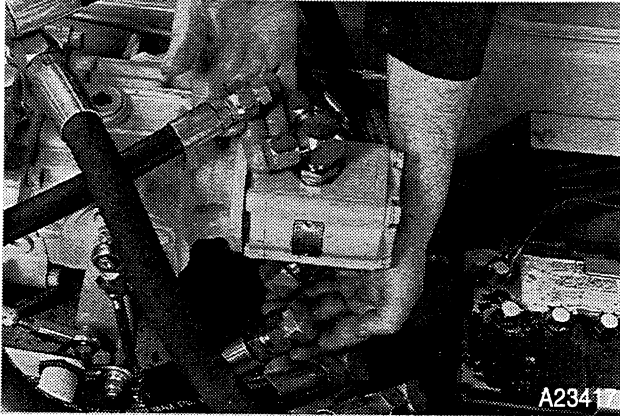

Disconnect the hoses to the inlet and outlet of the gear pump. Install plugs in the hoses and caps on the fittings.

STEP 16

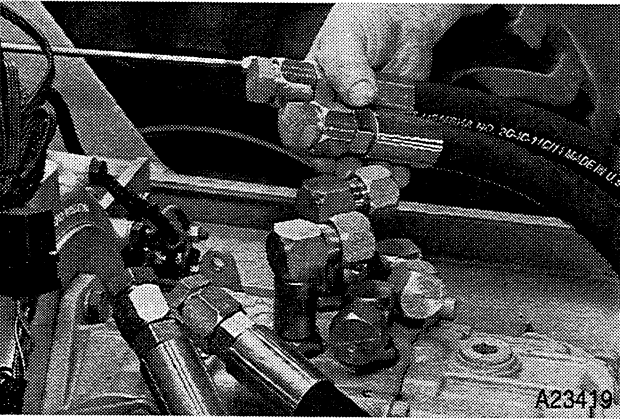

Disconnect the hoses at the work ports for the piston pumps. Install plugs in the hoses and caps on the fittings. Fasten identification tags to the hoses.

STEP 17

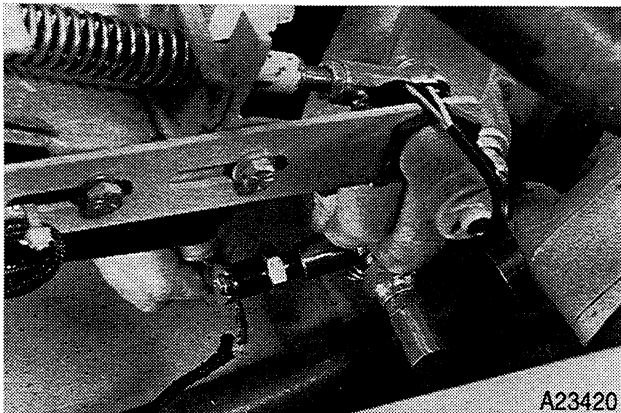

Disconnect the wire from the hydraulic oil temperature switch.

STEP 18

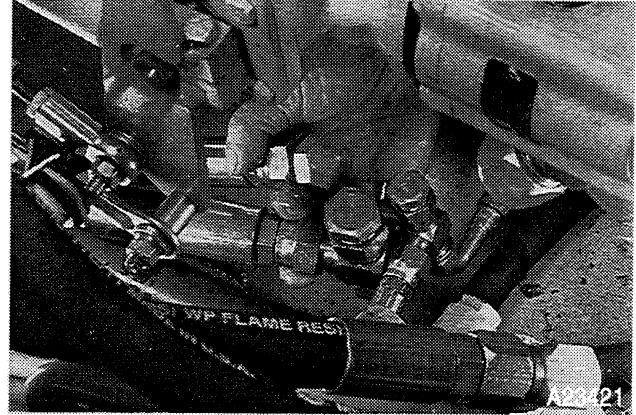

Disconnect the hoses under the piston pumps for the case drain and charge oil lines. Install plugs in the hoses and caps on the fittings.

STEP 19

Make sure all the plugs in the hoses are tight and turn the vacuum pump OFF.

STEP 20

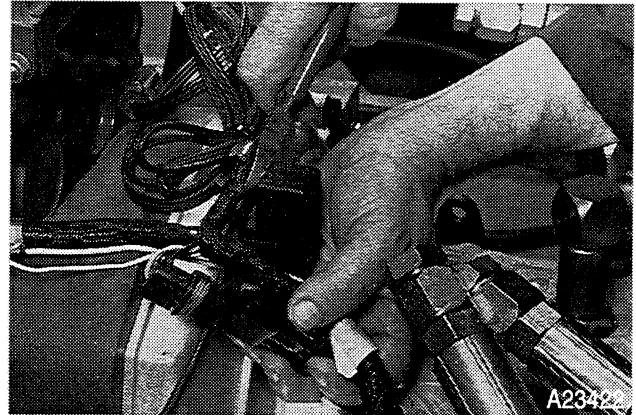

If the machine is equipped with a backup alarm, disconnect the harness connector and cut the tie strap holding the relay.

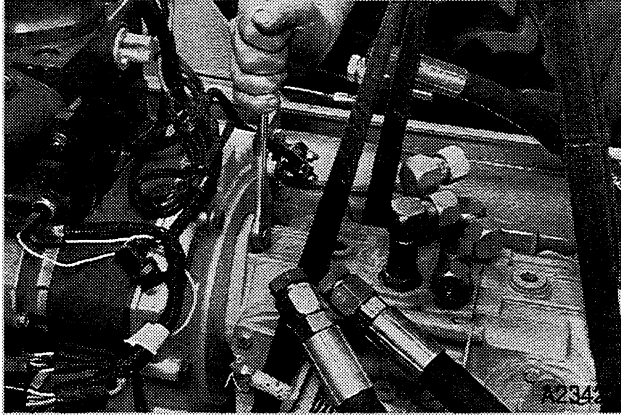
STEP 21

Fasten acceptable lifting equipment to the tandem pumps. Loosen and remove the cap screws that hold the tandem pumps.

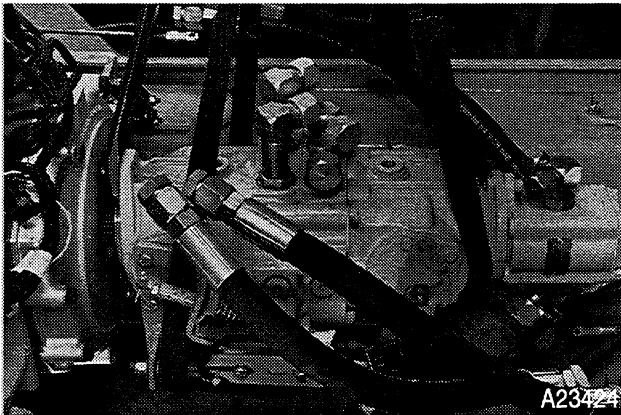
STEP 22

Use a prybar to help separate the tandem pumps from the mounting plate and drive coupling. Remove the tandem pumps.

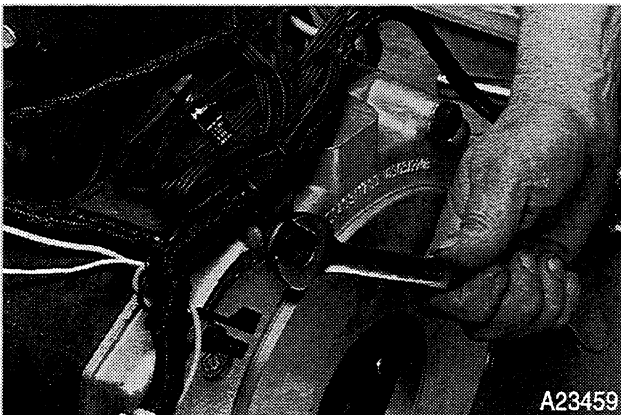
STEP 23

Loosen and remove cap screw for pump mount housing holding ground cable. Disconnect the ground cable from the engine.

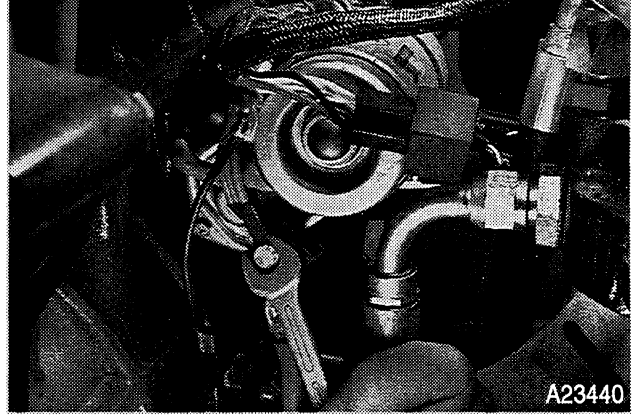
STEP 24

Disconnect the positive cable from the battery terminal on the starter.

STEP 25

Disconnect the wire from the fuel level sender.

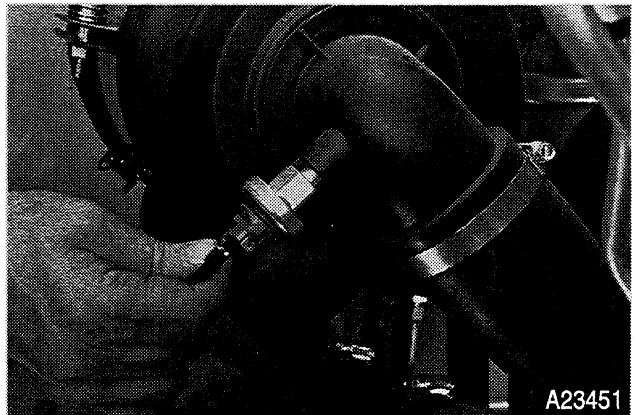
STEP 26

Disconnect the wires to the air filter condition switch.

STEP 27

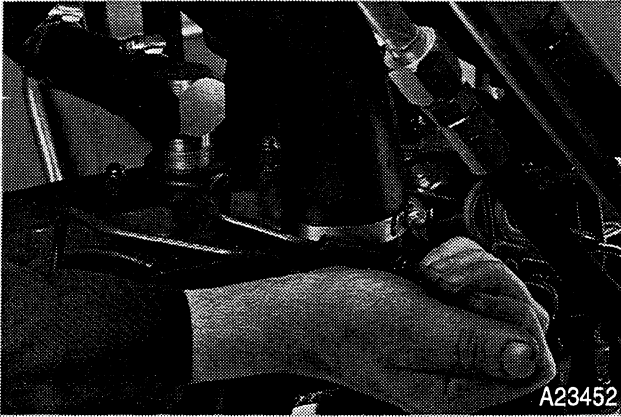

Loosen the clamp on the air cleaner hose at the intake manifold

STEP 28

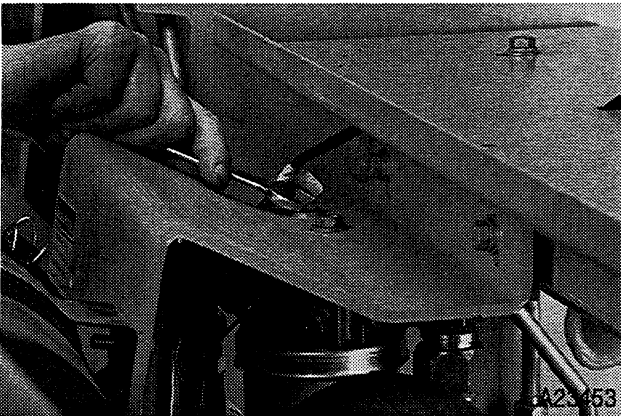

Loosen and remove the two cap screws fastening the hydraulic filter to the mounting bracket.

STEP 29

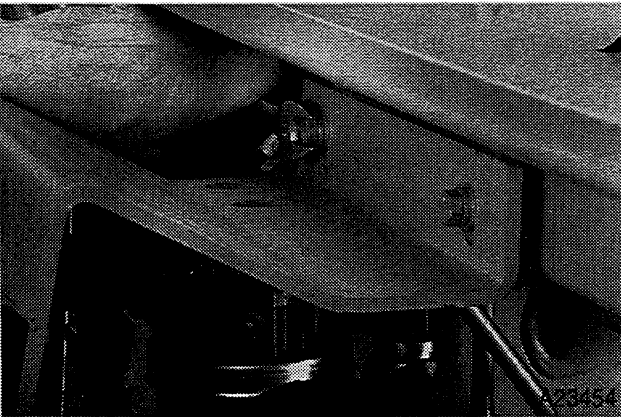

Loosen and remove the two cap screws fastening the mounting bracket to the frame. Remove the bracket and air cleaner as an assembly.

STEP 30

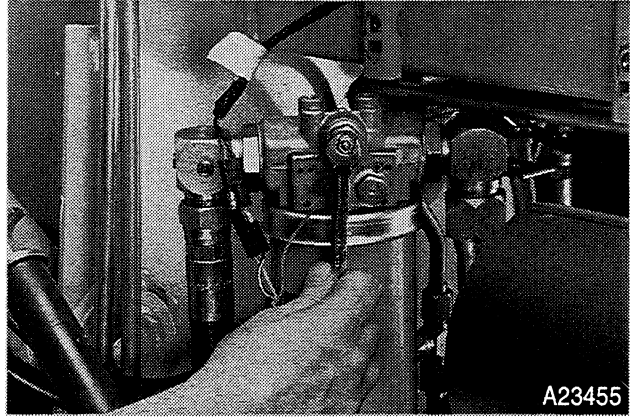

Disconnect the wire from the hydraulic oil filter. If the machine is equipped with a backup alarm, disconnect the connector for the backup alarm.

STEP 31

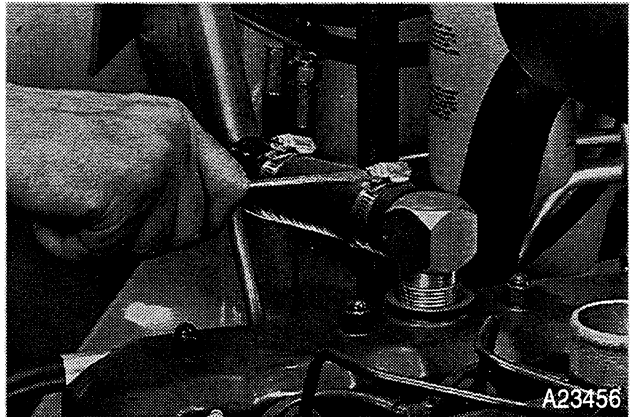

Loosen the clamp on the oil filler at the elbow in the valve cover. Remove the oil filler tube and hose.

STEP 32

Loosen and remove the four cap screws and flat washers which fasten the muffler flex coupling to the exhaust manifold.

STEP 33

Loosen and remove two cap screws and flat washers which fasten the muffler mounting bracket to the main frame. Remove the muffler and mounting bracket.

STEP 34

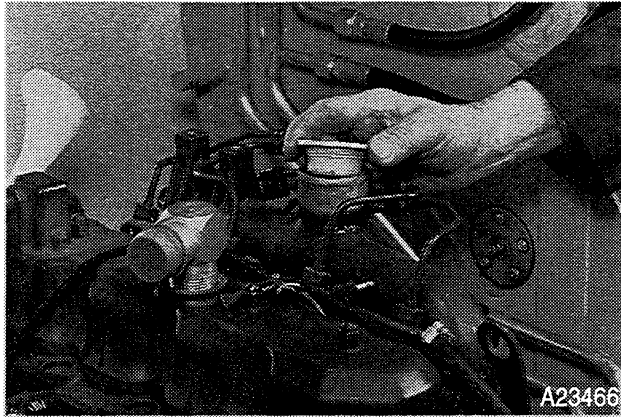

Cover or close the opening in the intake manifold and the oil filler elbow on the valve cover.

STEP 37

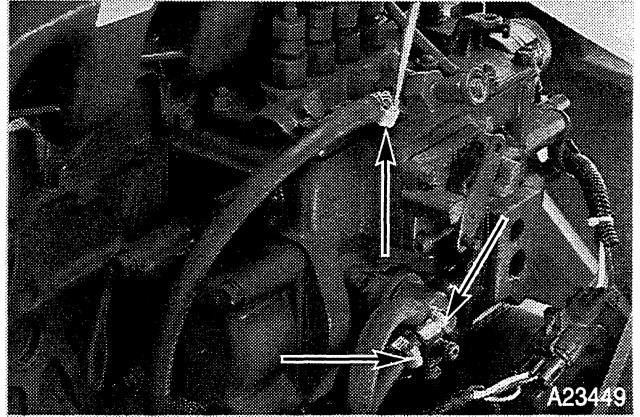

Loosen the hose clamps and remove the fuel line hoses at three places. Fasten identification tags to the hoses.

STEP 35

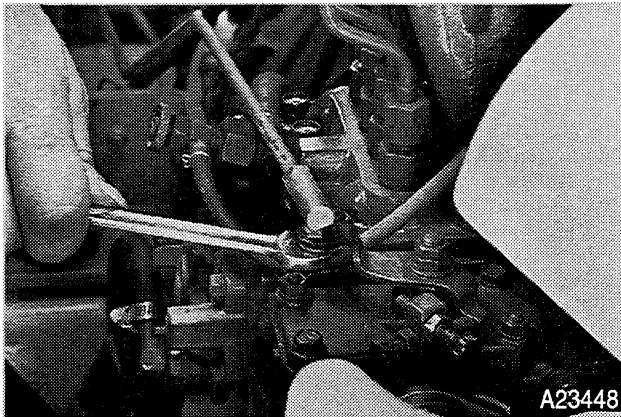

Loosen and remove the nut from the ball joint at the speed control lever for the injection pump. Remove the throttle rod.

STEP 38

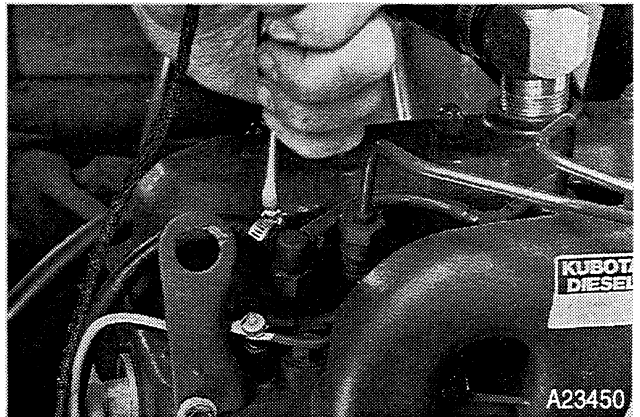

Loosen the hose clamp and remove the hose for the fuel return line. Keep the end of the hose above the level of fuel in the fuel tank to prevent leakage.

STEP 36

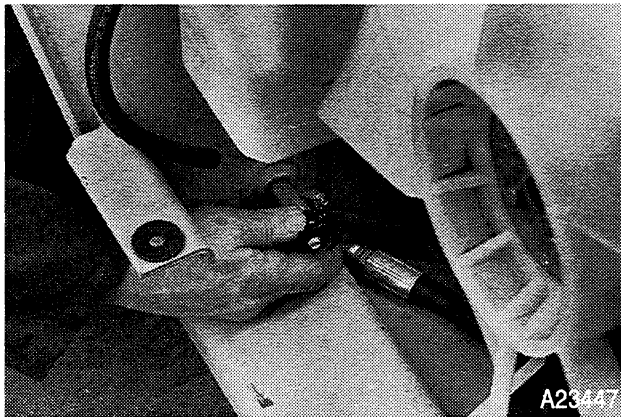

Close the shutoff valve for the fuel supply line.

STEP 39

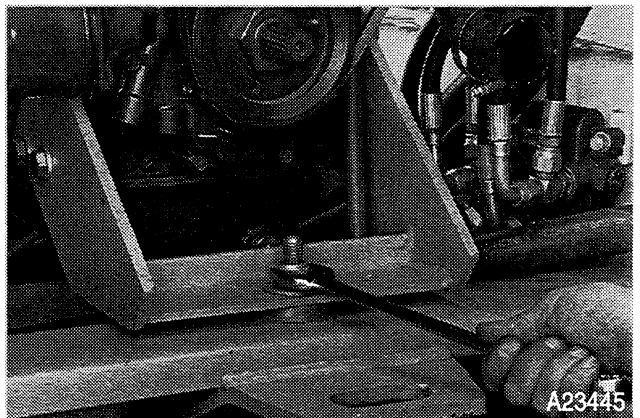

Loosen and remove the nut and cap screw for the rear engine mount.

STEP 40

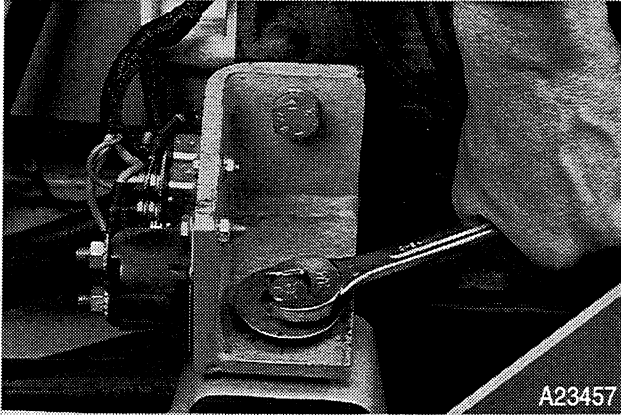

Loosen and remove the cap screw and nut for the left front engine mount.

STEP 42

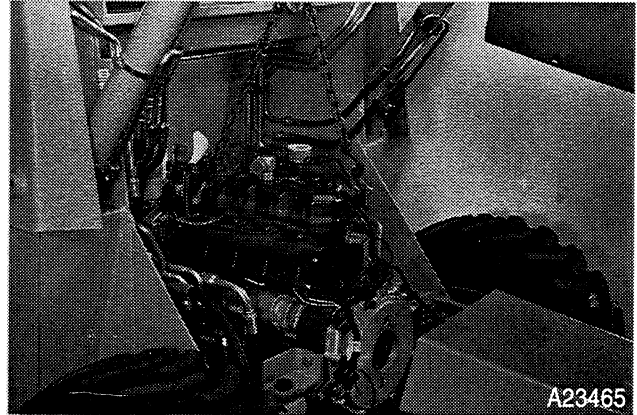

Attach a lifting sling to the lifting eyes on the engine. Remove the engine from the main frame.

STEP 41

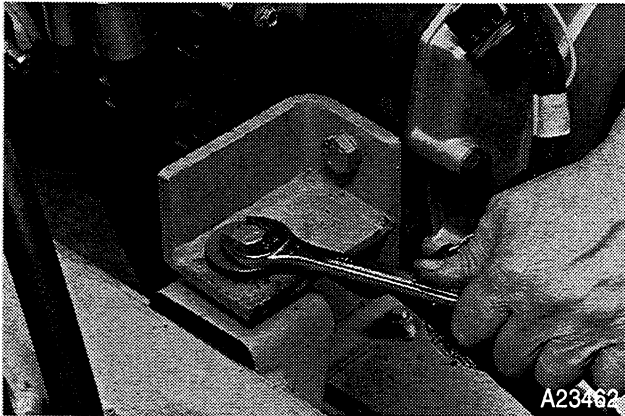

Loosen and remove the cap screw and nut for the right front engine mount.

ENGINE INSTALLATION

STEP 43

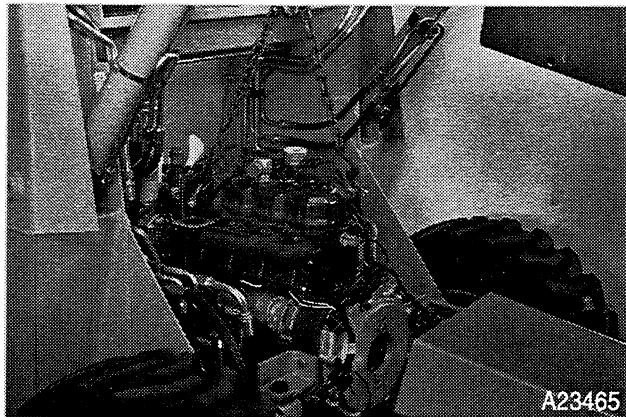

Lift the engine over the machine and lower the engine into place.

STEP 44

Install the flat washers, cap screws, lock washers and nuts finger tight for all three engine mounts.

STEP 45

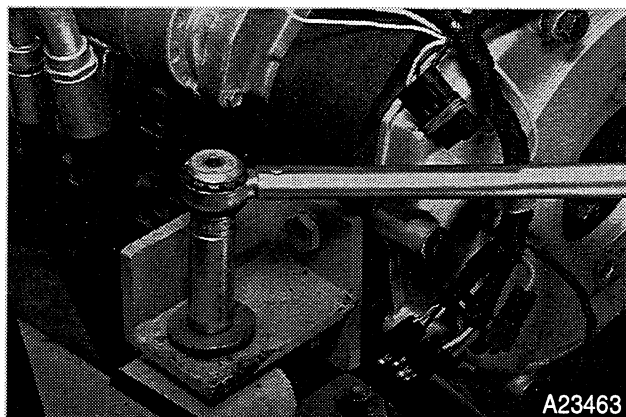

Tighten the cap screw and nut for the right front engine mount to a torque of 80 to 96 lb ft (109 to 130 Nm).

STEP 46

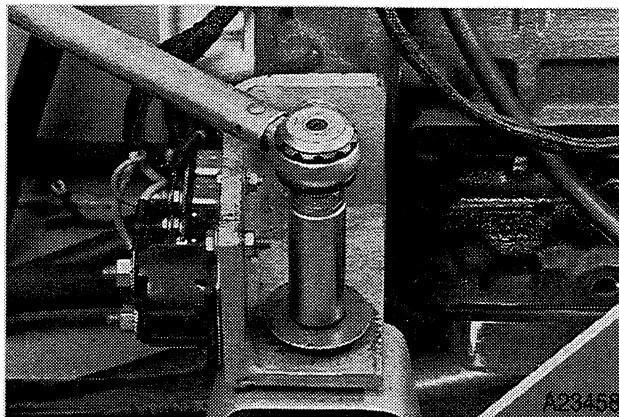

Tighten the cap screw and nut for the left front engine mount to a torque of 80 to 96 lb ft (109 to 130).

STEP 47

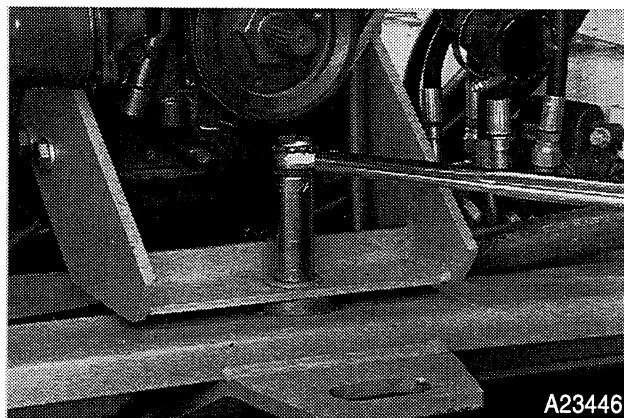

Tighten the nut and cap screw for the rear engine mount to a torque of 150 to 180 lb ft (203 to 244 Nm).

STEP 48

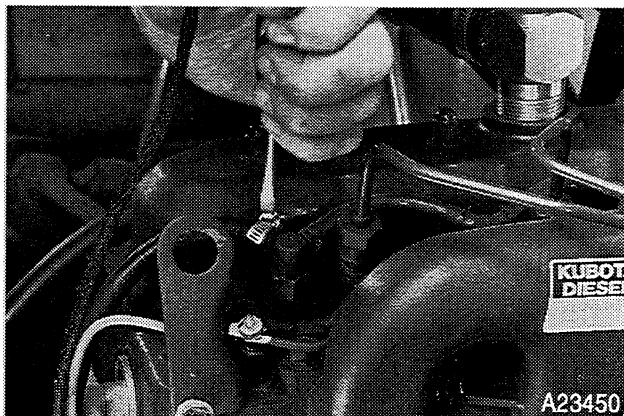

Install the hose for the fuel return line from the injectors and tighten the hose clamp.